

# How To: Diagnosis GPS backup battery

## Abstract

**Important note:** This procedure and the used tool suitable only for the Typhoon H (H480).

The small backup battery on the GNSS module (aka GPS module) is for keeping processor clock alive and hold received satellite data. At Typhoon H GNSS module it is rechargeable 3.1V (2.8 to 3.3V), 5.5mAh battery MS621FE.

If the drone is often in use it should be no problem. If it was longer stored without being powered on the battery may be discharged.

Charging on-board takes a very long time.

This is the on-board charging circuit:  
As we can see it will never reach 3V anymore.

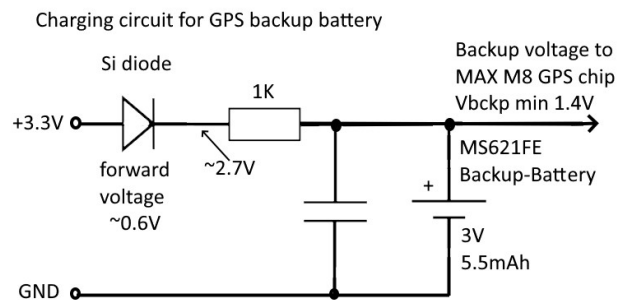

To check if there is a problem with the battery without opening the case of the drone we can use the GUI YTHtool.

YTHtool is a replacement of the old Typhoon H GUI. It offers a deeper insight how the flight controller interacts with its sensors and the GNSS module.

Download this tool from download area in my homepage:

<http://h-elsner.mooc.com/html/downl.htm>

Binaries for Windows and LINUX are available. For MacOS you must compile it by yourself. Source code is there.

Installation: No installation, simply unzip the file. It is a portable application. You need only the executable for your OS. Copy it somewhere in the home file system or to an USB stick.

## Connect YTHtool to the Typhoon H

1. Power up the drone, wait until it is fully booted up.
2. Connect the drone via data-capable micro USB cable to the PC.
3. Start the YTHtool. Used serial ports are listed in the text field on page "System / Settings". For Windows it should be the highest COM number. In most cases this should be the right COM port.  
For LINUX it should be /dev/ttyACM0.
4. Select the proper serial port and let baudrate at 115200. Then click on "Connect".

# Diagnosis GNSS module backup battery

Go to “GNSS information” page. Once the drone is connected to the YTHtool after a short time period when the GPS status message was received we can see following picture:

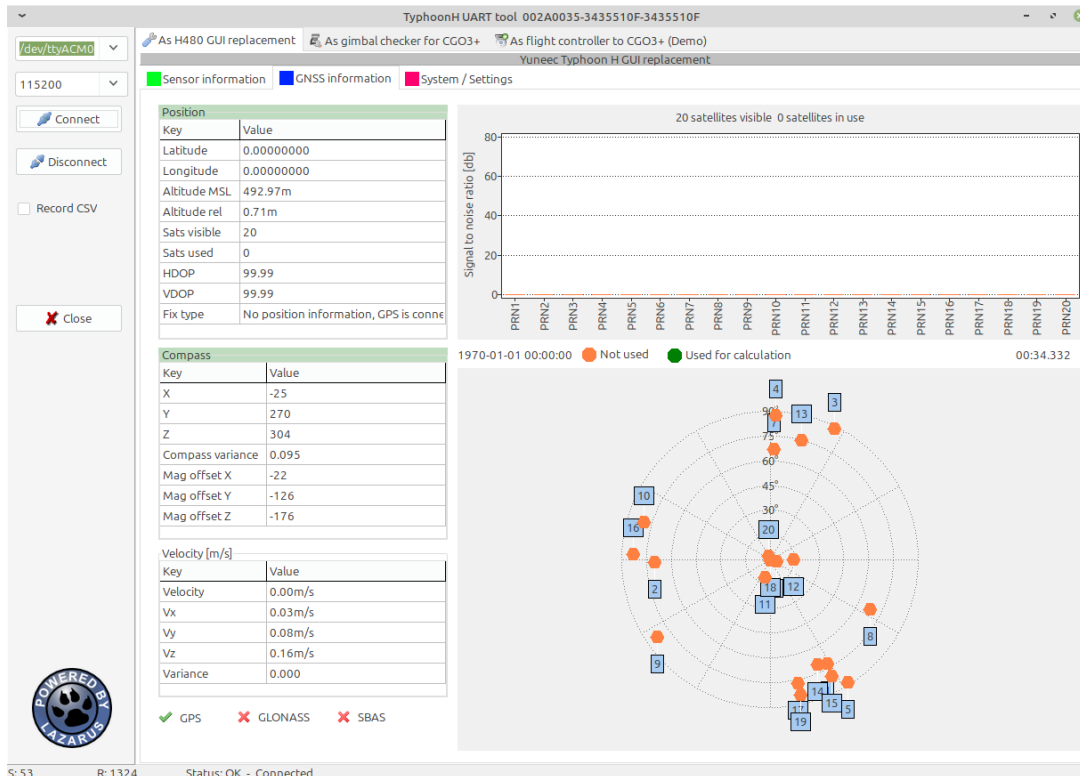

Figure1: Good backup battery

Although no satellites have been received yet, the GPS chip has already stored data from the satellites (ID, azimuth, elevation). Well, that’s good. The backup battery is in good condition.

The satellite data may be old and will be corrected when more satellites are received but this is normal. Depending where we are (indoor, outdoor, open area or not) more satellites should be received and in the best case used for calculation.

Also SBAS (Satellite Based Augmentation System) should go green. It provides correction values for timing and increases accuracy of positioning.

A bad battery will show the following picture:

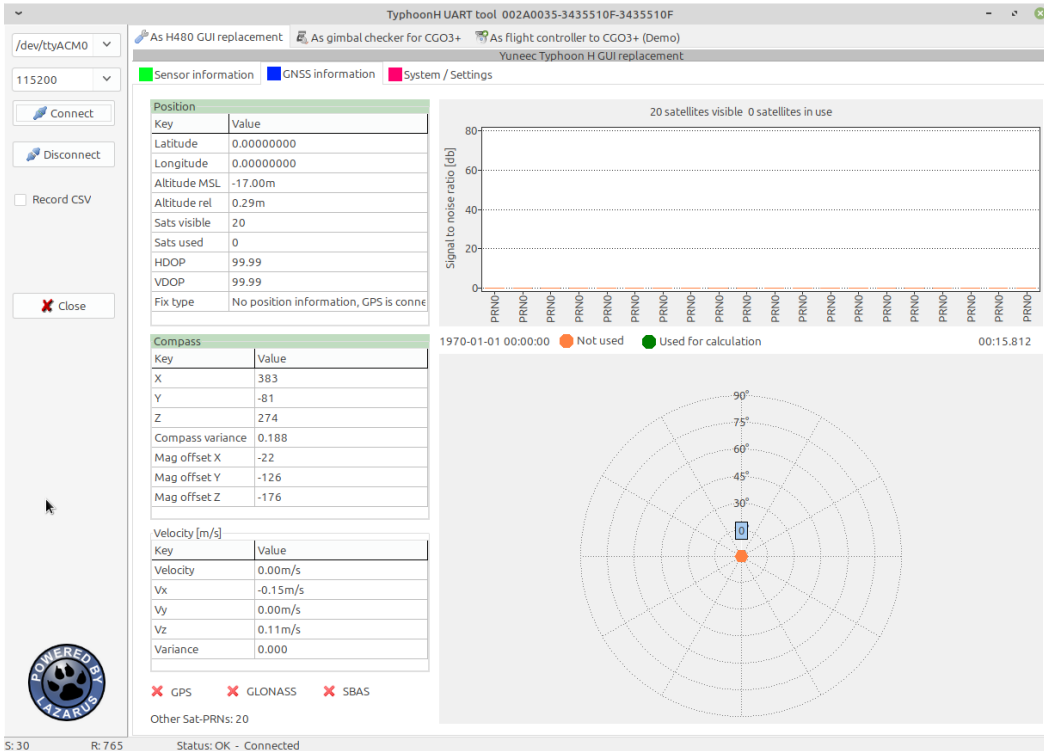

Figure 2: Bad backup battery

Satellite data are missing after power on. Possibly this is normal if the drone was stored for a long time. We have to test a little bit more. Wait until satellites have been received, satellite data were downloaded, and some satellites are in use for calculation.

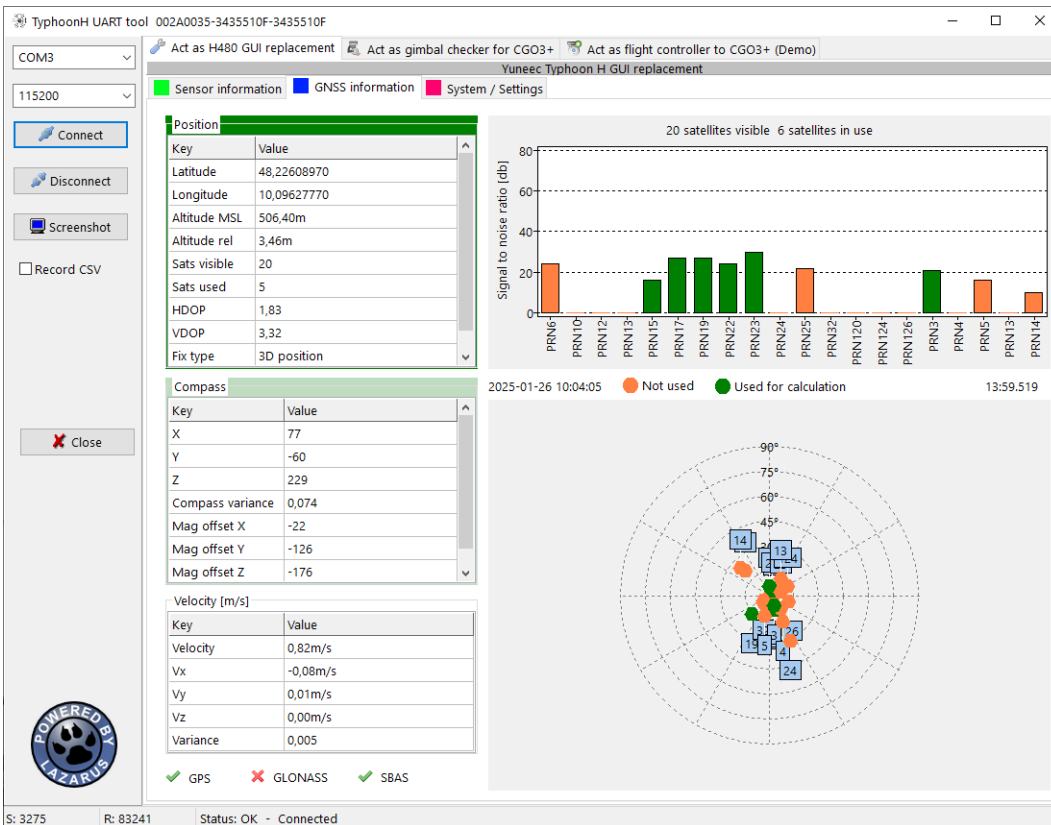

Figure 3: Satellites in use, SBAS satellites available

This may take some time (12min or more). Indoor this may be impossible. Try it outdoor in open area (no need to keep the YTHtool connected). Let the drone powered on for some hours. Remove the camera before to save battery capacity.

Power off, wait some time and power on again. If we get the bad battery picture again (no satellite data available) the battery on the GNSS module needs to be replaced. If the satellite data are still there, this is a good sign. The battery was charged a little bit. Let the drone some days alone and check again. If satellite are lost the battery is bad. If the satellite data is still available (Figure 1: Good battery) then the backup battery was charged and seems to be OK.

You should fly your drone as often as possible or at least power it on from time to time to keep the backup battery charged. Check GNSS status and other sensors from time to time with YTHtool.

Questions or comments are welcome in [Yuneec drone forum](#).

Have fun!